

Forme costruttive di serie



forma B



forma S



forma D

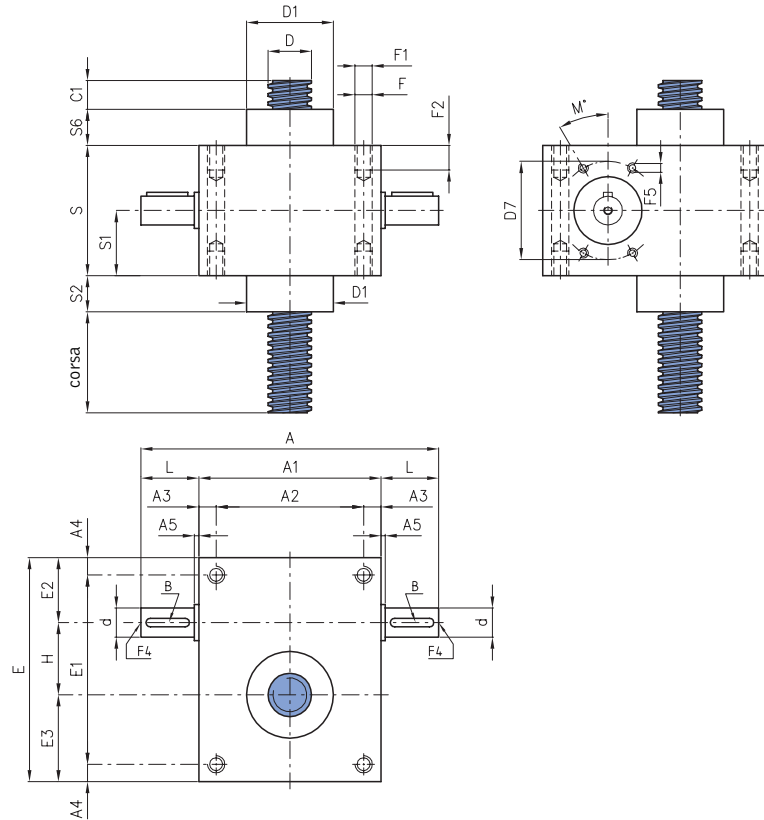

Grandezza	Modelli TP							
	Modelli XTP*				559	7010	8010	9010
A	118	150	206	270	270	350	350	390
A1	70	100	126	160	170	230	230	250
A2	56	80	102	130	134	180	180	200
A3	7	10	12	15	18	25	25	25
A4	7	7,5	12	15	18	25	25	25
A5	4	-	-	-	-	-	-	-
B	3x3x15	4x4x20	6x6x30	8x7x40	8x7x40	8x7x50	8x7x50	12x8x60
C1	15	15	20	25	25	25	25	40
d Ø j6	9	12	20	25	25	30	30	40
D Ø	18x3	20x4	30x6	40x7	55x9	70x10	80x10	100x12
D1 Ø _{0,2} ^{3,2}	30	44	60	69	90	120	120	150
D7 Ø	-	60	68	86	86	74	74	100
E	94	100	155	195	211	280	280	320
E1	80	85	131	165	175	230	230	270
E2	29	32,5	45	50	63	75	75	85
E3	35	37,5	60	75	78	115	115	125
F Ø	9	9	11	13	-	-	-	-
F1	-	-	-	-	M20	M30	M30	M30
F2	-	-	-	-	30	45	45	45
F4	-	M5x10	M6x12	M8x15	M8x15	M10x18	M10x18	M10x18
F5 (n° fori)	-	M5x12(4)	M6x12(4)	M8X16(4)	M8X16(4)	M8x15(6)	M8x15(6)	M10x18(4)
H	30	30	50	70	70	90	90	110
L	24	25	40	55	50	60	60	70
M [°]	-	30	45	30	30	30	30	45
S	50	70	90	120	150	176	176	230
S1	25	35	45	60	75	88	88	115
S2	10	20	25	35	40	40	40	50
S6	10	20	25	35	40	40	40	50

* Modello XTP: versione in acciaio inossidabile



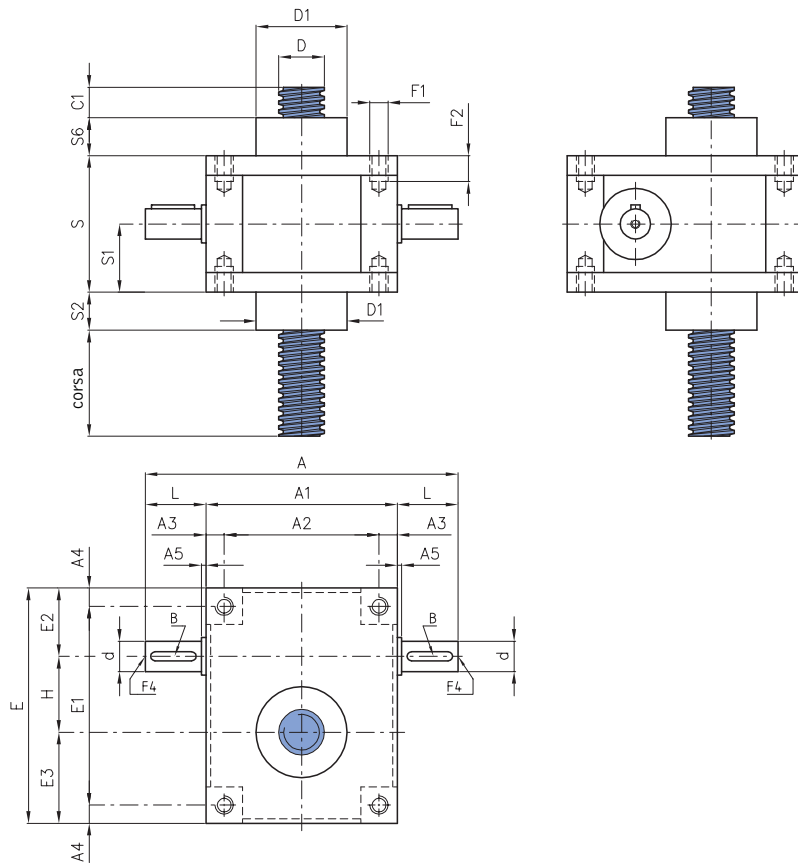

Forme costruttive di serie



forma B



forma S



forma D

Modelli TP extra pesanti

Grandezza	10012	12014	14014	16016	20018	25022
A	490	490	780	780	920	920
A1	320	320	500	500	600	600
A2	230	230	360	360	470	470
A3	45	45	70	70	65	65
A4	25	25	40	40	60	60
A5	5	5	10	10	20	20
B	16x10x70	16x10x70	20x12x110	20x12x110	28x16x120	28x16x120
C1	40	40	50	50	50	50
d Ø j6	55	55	70	70	100	100
D Ø	100x12	120x14	140x14	160x16	200x18	250x22
D1 Ø _{-0,2} ^{+0,2}	210	210	300	300	370	370
E	405	405	590	590	780	780
E1	355	355	510	510	660	660
E2	105	105	160	160	220	220
E3	160	160	230	230	310	310
F1	M30	M30	M56	M56	M64	M64
F2	45	45	110	110	130	130
F4	M12x25	M12x25	M14x30	M14x30	M16x35	M16x35
H	140	140	200	200	250	250
L	85	85	140	140	160	160
S	270	270	370	370	480	480
S1	135	135	185	185	240	240
S2	50	50	60	60	60	60
S6	50	50	60	60	60	60

Forme costruttive di serie



forma B



forma S



forma D

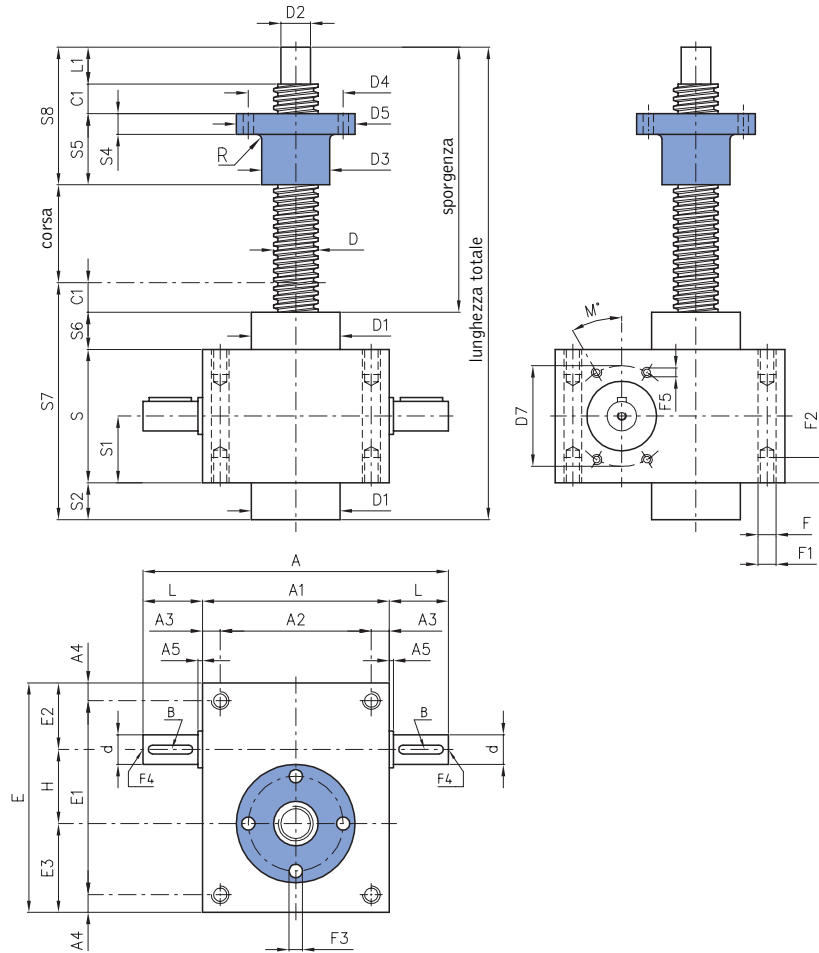

Grandezza	Modelli TPR							
	Modelli XTPR*							
	183	204	306	407	559	7010	8010	9010
A	118	150	206	270	270	350	350	390
A1	70	100	126	160	170	230	230	250
A2	56	80	102	130	134	180	180	200
A3	7	10	12	15	18	25	25	25
A4	7	7,5	12	15	18	25	25	25
A5	4	-	-	-	-	-	-	-
B	3x3x15	4x4x20	6x6x30	8x7x40	8x7x40	8x7x50	8x7x50	12x8x60
C1	15	15	20	25	25	25	25	40
d Ø j6	9	12	20	25	25	30	30	40
D Ø	18x3	20x4	30x6	40x7	55x9	70x10	80x10	100x12
D1 Ø _{0,03}	30	44	60	69	90	120	120	150
D2 Ø k6	12	15	20	25	40	55	60	70
D3 Ø	26	32	46	60	76	100	110	150
D4 Ø	40	45	64	78	100	140	150	190
D5 Ø	54	60	80	96	130	180	190	230
D7 Ø	-	60	68	86	86	74	74	100
E	94	100	155	195	211	280	280	320
E1	80	85	131	165	175	230	230	270
E2	29	32,5	45	50	63	75	75	85
E3	35	37,5	60	75	78	115	115	125
F Ø	9	9	11	13	-	-	-	-
F1	-	-	-	-	M20	M30	M30	M30
F2	-	-	-	-	30	45	45	45
F3 (4 fori)	7	7	7	9	13	18	18	20
F4	-	M5x10	M6x12	M8x15	M8x15	M10x18	M10x18	M10x18
F5 (n° fori)	-	M5x12 (4)	M6x12 (4)	M8x16 (4)	M8x16 (4)	M8x15 (6)	M8x15 (6)	M10x18 (4)
H	30	30	50	70	70	90	90	110
L	24	25	40	55	50	60	60	70
L1	14	20	25	30	45	70	75	80
M [°]	-	30	45	30	30	30	30	45
R (raggio)	3	3	3	3	3	3	3	3
S	50	70	90	120	150	176	176	230
S1	25	35	45	60	75	88	88	115
S2	10	20	25	35	40	40	40	50
S4	12	12	14	16	20	30	30	45
S5	45	45	48	75	100	105	110	135
S6	10	20	25	35	40	40	40	50
S7	85	125	160	215	255	281	281	370
S8	74	80	93	130	170	200	210	255

* Modelli XTPR: versione in acciaio inossidabile



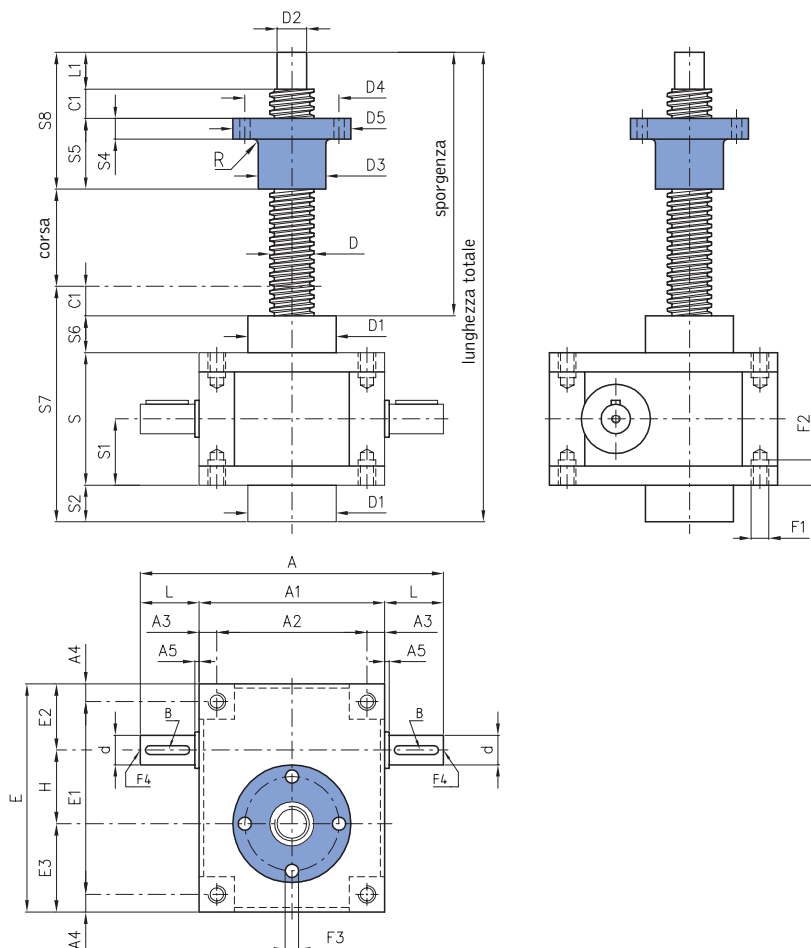

Forme costruttive di serie



forma B



forma S



forma D

Modelli TPR extra pesanti

Grandezza	10012	12014	14014	16016	20018	25022
A	490	490	780	780	920	920
A1	320	320	500	500	600	600
A2	230	230	360	360	470	470
A3	45	45	70	70	65	65
A4	25	25	40	40	60	60
A5	5	5	10	10	20	20
B	16x10x70	16x10x70	20x12x110	20x12x110	28x16x120	28x16x120
C1	40	40	50	50	50	50
d Ø j6	55	55	70	70	100	100
D Ø	100x12	120x14	140x14	160x16	200x18	250x22
D1 Ø _{0.3}	210	210	300	300	370	370
D2 Ø k6	70	90	120	130	160	200
D3 Ø	150	180	210	210	310	310
D4 Ø	190	235	270	270	400	400
D5 Ø	230	280	320	320	480	480
E	405	405	590	590	780	780
E1	355	355	510	510	660	660
E2	105	105	160	160	220	220
E3	160	160	230	230	310	310
F1	M30	M30	M56	M56	M64	M64
F2	45	45	110	110	130	130
F3 (n° fori)	20 (4)	25 (4)	25 (6)	25 (6)	45 (6)	45 (6)
F4	M12x25	M12x25	M14x30	M14x30	M16x35	M16x35
H	140	140	200	200	250	250
L	85	85	140	140	160	160
L1	80	85	120	120	160	180
R (raggio)	3	3	4	4	5	5
S	270	270	370	370	480	480
S1	135	135	185	185	240	240
S2	50	50	60	60	60	60
S4	45	55	80	80	100	100
S5	135	160	250	250	300	300
S6	50	50	60	60	60	60
S7	410	410	540	540	650	650
S8	255	285	420	420	510	530