

Forme costruttive di base:

rapporto:
1/1

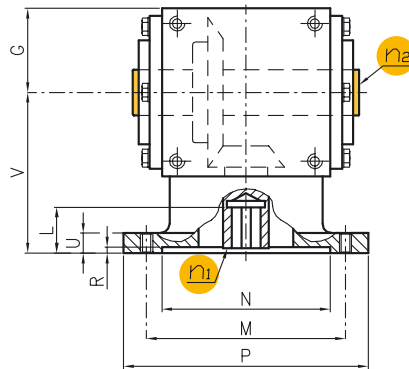

rapporto:
1/1,5 - 1/2 - 1/3 - 1/4

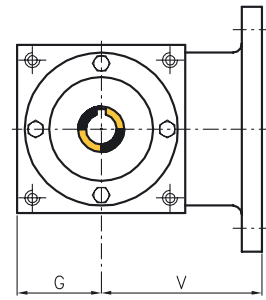
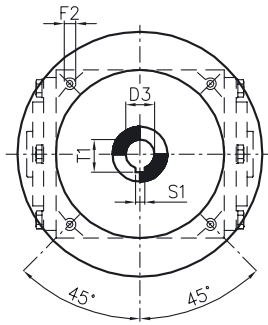

Motorinvio ad albero cavo MRC

Grandezza	Flangia IEC	D3 H7	F2	G	L	M	N	P	R	S1	T1	U	V	
Modelli XMRC*	86	56 B5	9	M6	43	23	100	80	120	4	3	10,4	13	90
		63 B5	11	M8	43	23	115	95	140	4	4	12,8	13	90
		71 B5	14	M8	43	30	130	110	160	4	5	16,3	13	90
		71 B14	14	7	43	30	85	70	105	4	5	16,3	13	90
		80 B5	19	M10	43	40	165	130	200	4	6	21,8	13	100
		80 B14	19	7	43	40	100	80	120	4	6	21,8	13	100
	110	63 B5	11	M8	55	23	115	95	140	4	4	12,8	13	105
		71 B5	14	M8	55	30	130	110	160	4	5	16,3	13	105
		71 B14	14	7	55	30	85	70	105	4	5	16,3	13	105
		80 B5	19	M10	55	40	165	130	200	4	6	21,8	13	105
		80 B14	19	7	55	40	100	80	120	4	6	21,8	13	105
		134	71 B5	14	M8	67	30	130	110	160	5	5	16,3	13
	80 B5		19	M10	67	40	165	130	200	5	6	21,8	13	125
	80 B14		19	7	67	40	100	80	120	5	6	21,8	13	125
90 B5	24		M10	67	50	165	130	200	5	8	27,3	13	125	
90 B14	24		9	67	50	115	95	140	5	8	27,3	13	125	
100-112 B5	28		M12	67	60	215	180	250	5	8	31,3	13	135	
166	100-112 B14	28	9	67	60	130	110	160	5	8	31,3	13	135	
	71 B5	14	9	83	30	130	110	160	6	5	16,3	15	160	
	80 B5	19	M10	83	40	165	130	200	6	6	21,8	15	160	
	90 B5	24	M10	83	50	165	130	200	6	8	27,3	15	160	
	100-112 B5	28	M12	83	60	215	180	250	6	8	31,3	15	160	
200	100-112 B14	28	9	83	60	130	110	160	6	8	31,3	15	160	
	90 B5	24	11	100	50	165	130	200	6	8	27,3	23	220	
	100-112 B5	28	M12	100	60	215	180	250	6	8	31,3	23	220	
	132 B5	38	M12	100	80	265	230	300	6	10	41,3	23	220	
250	132 B14	38	11	100	80	165	130	200	6	10	41,3	23	220	
	132 B5	38	M12	125	80	265	230	300	6	10	41,3	25	250	
	132 B14	38	11	125	80	165	130	200	6	10	41,3	25	250	
	160 B5	42	M16	125	110	300	250	350	6	12	45,8	25	250	

* Modello XMRC: versione in acciaio inossidabile

Per le dimensioni non quotate si faccia riferimento agli schemi di pagina 198



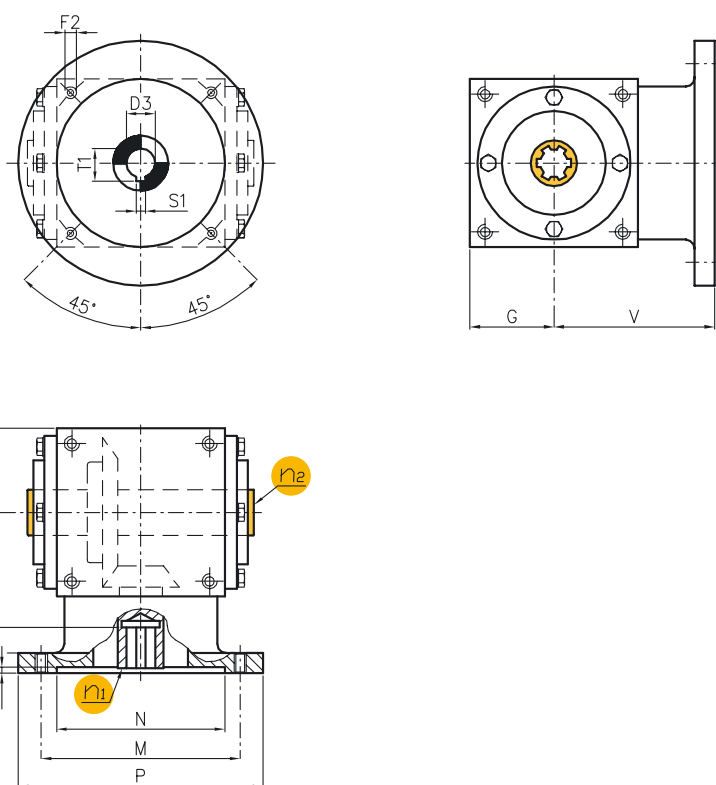

Forme costruttive di base:

rapporto:
1/1



MC1

rapporto:
1/1,5 - 1/2 - 1/3 - 1/4



MC2

Motorino ad albero cavo brocciato MRB

Grandezza	Flangia IEC	D3 H7	F2	G	L	M	N	P	R	S1	T1	U	V	
Modelli XMRB*	86	56 B5	9	M6	43	23	100	80	120	4	3	10,4	13	90
		63 B5	11	M8	43	23	115	95	140	4	4	12,8	13	90
		71 B5	14	M8	43	30	130	110	160	4	5	16,3	13	90
		71 B14	14	7	43	30	85	70	105	4	5	16,3	13	90
		80 B5	19	M10	43	40	165	130	200	4	6	21,8	13	100
		80 B14	19	7	43	40	100	80	120	4	6	21,8	13	100
	110	63 B5	11	M8	55	23	115	95	140	4	4	12,8	13	105
		71 B5	14	M8	55	30	130	110	160	4	5	16,3	13	105
		71 B14	14	7	55	30	85	70	105	4	5	16,3	13	105
		80 B5	19	M10	55	40	165	130	200	4	6	21,8	13	105
		80 B14	19	7	55	40	100	80	120	4	6	21,8	13	105
		134	71 B5	14	M8	67	30	130	110	160	5	5	16,3	13
	80 B5		19	M10	67	40	165	130	200	5	6	21,8	13	125
	80 B14		19	7	67	40	100	80	120	5	6	21,8	13	125
	90 B5		24	M10	67	50	165	130	200	5	8	27,3	13	125
	90 B14		24	9	67	50	115	95	140	5	8	27,3	13	125
100-112 B5	28		M12	67	60	215	180	250	5	8	31,3	13	135	
166	100-112 B14	28	9	67	60	130	110	160	5	8	31,3	13	135	
	71 B5	14	9	83	30	130	110	160	6	5	16,3	15	160	
	80 B5	19	M10	83	40	165	130	200	6	6	21,8	15	160	
	90 B5	24	M10	83	50	165	130	200	6	8	27,3	15	160	
	100-112 B5	28	M12	83	60	215	180	250	6	8	31,3	15	160	
	100-112 B14	28	9	83	60	130	110	160	6	8	31,3	15	160	
200	90 B5	24	11	100	50	165	130	200	6	8	27,3	23	220	
	100-112 B5	28	M12	100	60	215	180	250	6	8	31,3	23	220	
	132 B5	38	M12	100	80	265	230	300	6	10	41,3	23	220	
	132 B14	38	11	100	80	165	130	200	6	10	41,3	23	220	
250	132 B5	38	M12	125	80	265	230	300	6	10	41,3	25	250	
	132 B14	38	11	125	80	165	130	200	6	10	41,3	25	250	
	160 B5	42	M16	125	110	300	250	350	6	12	45,8	25	250	

* Modello XMRB: versione in acciaio inossidabile

Per le caratteristiche dell'albero brocciato, si faccia riferimento ai modelli RB a pagina 200
Per le dimensioni non quotate si faccia riferimento agli schemi di pagina 200

Forme costruttive di base:

rapporto:
1/1



MC1

rapporto:
1/1,5 - 1/2 - 1/3 - 1/4



MC2

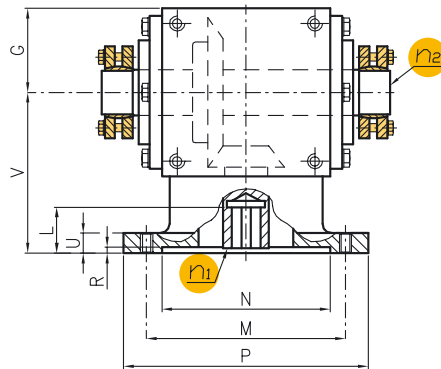
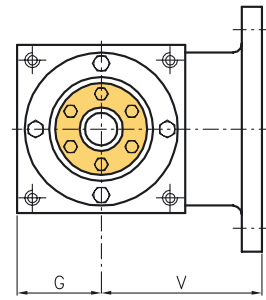
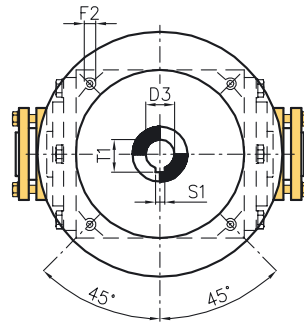

Motorinvio ad albero cavo con calettatori MRA

Grandezza	Flangia IEC	D3 H7	F2	G	L	M	N	P	R	S1	T1	U	V	
Modelli XMRA*	86	56 B5	9	M6	43	23	100	80	120	4	3	10,4	13	90
		63 B5	11	M8	43	23	115	95	140	4	4	12,8	13	90
		71 B5	14	M8	43	30	130	110	160	4	5	16,3	13	90
		71 B14	14	7	43	30	85	70	105	4	5	16,3	13	90
		80 B5	19	M10	43	40	165	130	200	4	6	21,8	13	100
		80 B14	19	7	43	40	100	80	120	4	6	21,8	13	100
	110	63 B5	11	M8	55	23	115	95	140	4	4	12,8	13	105
		71 B5	14	M8	55	30	130	110	160	4	5	16,3	13	105
		71 B14	14	7	55	30	85	70	105	4	5	16,3	13	105
		80 B5	19	M10	55	40	165	130	200	4	6	21,8	13	105
		80 B14	19	7	55	40	100	80	120	4	6	21,8	13	105
		134	71 B5	14	M8	67	30	130	110	160	5	5	16,3	13
	80 B5		19	M10	67	40	165	130	200	5	6	21,8	13	125
	80 B14		19	7	67	40	100	80	120	5	6	21,8	13	125
	90 B5		24	M10	67	50	165	130	200	5	8	27,3	13	125
	90 B14		24	9	67	50	115	95	140	5	8	27,3	13	125
100-112 B5	28		M12	67	60	215	180	250	5	8	31,3	13	135	
166	100-112 B14	28	9	67	60	130	110	160	5	8	31,3	13	135	
	71 B5	14	9	83	30	130	110	160	6	5	16,3	15	160	
	80 B5	19	M10	83	40	165	130	200	6	6	21,8	15	160	
	90 B5	24	M10	83	50	165	130	200	6	8	27,3	15	160	
	100-112 B5	28	M12	83	60	215	180	250	6	8	31,3	15	160	
200	100-112 B14	28	9	83	60	130	110	160	6	8	31,3	15	160	
	90 B5	24	11	100	50	165	130	200	6	8	27,3	23	220	
	100-112 B5	28	M12	100	60	215	180	250	6	8	31,3	23	220	
	132 B5	38	M12	100	80	265	230	300	6	10	41,3	23	220	
250	132 B14	38	11	100	80	165	130	200	6	10	41,3	23	220	
	132 B5	38	M12	125	80	265	230	300	6	10	41,3	25	250	
	132 B14	38	11	125	80	165	130	200	6	10	41,3	25	250	
	160 B5	42	M16	125	110	300	250	350	6	12	45,8	25	250	

* Modello XMRA: versione in acciaio inossidabile

Per le caratteristiche dei calettatori, si faccia riferimento ai modelli RA a pagina 201
Per le dimensioni non quotate si faccia riferimento agli schemi di pagina 201

